

OIL-ON-WATER MONITOR

 Models: **SODL-20** (Explosion-proof type)
ODL-20 (Non-explosion-proof type)

The Model (S)ODL-20 monitors a water surface for the presence of an oil film. The instrument projects a laser beam onto the water surface and measures the differences in the reflection properties between water and oil. Typical applications include providing intake protection for water treatment facilities and for monitoring industrial effluent. This model is part of a family of oil-on-water monitors which includes the Model (S)ODL-12 (laser-based, increased mechanical protection) and the Model OF-10 (LED based, low cost). The Model (S)ODL has been developed to provide high performance in a lightweight package allowing easier installation and routine maintenance work. An intrinsically safe version (IEC certified) of this instrument is also available allowing installation in hazardous areas.

FEATURES

- Non-contact detection by laser beam.
- Lightweight package for easier installation.
- Instrument not affected by water level variations within 0.3~2.0m range.
- Microprocessor based controller.
- Improved optical filtration minimises effects of sunlight on measurement.
- Extended service life of 2 years for the laser source.
- Intrinsically safe explosion protection available.

STANDARD SPECIFICATION

Product Name	: Oil on water monitor.
Model	: SODL-20 (explosion proof type) ODL-20 (Non-explosion proof type)
Measurement Objective	: Oil slick on water surface.
Measurement Method	: Reflectance measurement of visible light.
Installation Distance	: 0.3 to 2m (above water surface).
Light Source	: Semiconductor laser diode.
Loop Structure	: Individual detector and converter max. distance for installation is 15m.
Explosion Protection	: Intrinsically safe explosion proof structure.
Water Protection Standard	: Ingressive grade 3 (rain proof structure) according to JIS C 0920-1993.
Ambient Temperature	: 0 to 40°C.



Sample Water Temperature	: Above freezing point.
Output Signals	: Normal conditions: 18mA (±0.2mA)
Oil slick present	: 20mA (±0.2 mA)
Instrument Fault	: 16 mA (±0.2 mA)
Output Signal Load	: 300 Ω (min)~450 Ω (max) (including zener barrier)
Power Source	: DC 24V ±1V.
Power Consumption	: Max. 0.6VA.
Weight	
Transmitter (Convertor)	: 2 kg (approx.)
Detector	: 5 kg (approx.)
Standard Colour	: Blue (Munsell 10B5/10).
Cable Entry	: NPT 1/2 F (blanking plugs included)
Other Functions	
• Zero & span calibration functions,	
• Light source diagnostic functions	
• Measurement optimisation set-up functions.	

OPERATING PRINCIPLES & OVERVIEW

The reflectance of light from an oil film is greater than that of water. When an oil film is present on a water surface, it gives a "glistening" effect. From this property, the presence of oil can be detected by applying a light beam of constant intensity to the water surface and then measuring the intensity of the reflected light.

The sensor section is mounted above the water surface and contains a semiconductor laser, a precision-manufactured mirror (parabolic section) and a photodiode light sensor.

A pulsed light beam is emitted from the light source and is reflected back by the water surface to a mirror which is a section of a parabolic mirror. This part-parabolic mirror causes all light beams that are parallel to its optical axis to be reflected to the focal point. The photodiode light sensor is placed at this focal point because at this position, the effect of water level height variation on the light intensity is minimised. To remove interference caused by other light sources such as sunlight, the light source emits a pulsed light beam at a tuned frequency

ODL20

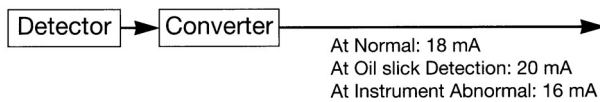

SODL20

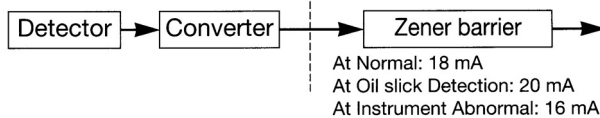

The collected light is then converted to an electrical signal and is further processed by the controller section. Under normal operations (no oil) the controller outputs an 18 mA signal. When oil is detected, the output signal changes to 20mA. In case of an analyser fault such as light source failure or interference from floating objects on the water surface, the output signal changes to 16 mA.

Semiconductor Laser Diode

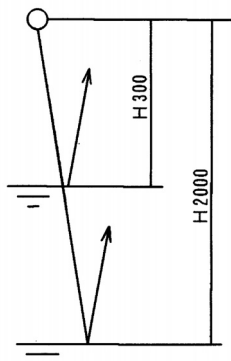

Parabolic Reflector

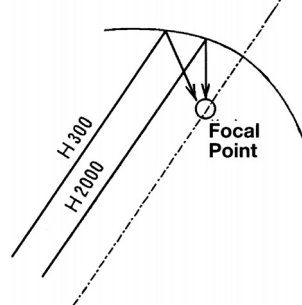

CONTROLLER FUNCTIONS

• LCD Display

RUN : Shows normal water surface and that the instrument is functioning correctly.

OIL Alarm : Alerts detection of an oil slick. It automatically returns back to normal when the oil film is no longer present on the water surface.

ERR Alarm : Indicates that normal measurement cannot be performed due to the light source failure or light being blocked by floating objects on the water surface. In either case the alarm must be reset manually after checking that the above causes have been rectified.

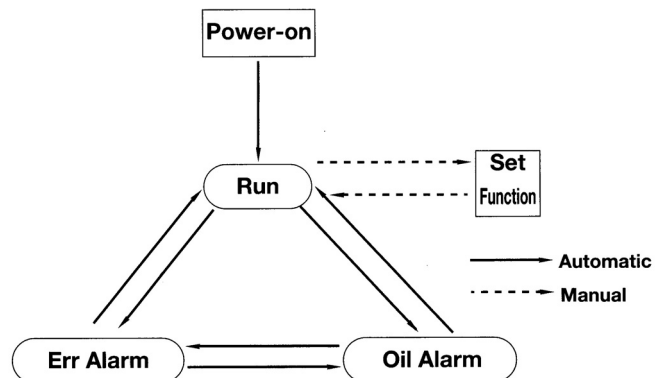

OTHER FUNCTIONS

• Zero span calibration

This function takes the light source shut off as a zero signal and oil film detection as a span signal for calibration. For zero calibration, cover the lower edge of the detector with a low - reflectance black film, etc. and input the zero signal through key operation. For span calibration, fill an accessory calibration vessel with water and float oil on it, and input the span signal through the key operation as with zero calibration.

• Light source diagnostic function (Err Alarm)

The service life of the light source is approx. 2 years but it may vary depending on the working conditions. If the light source lamp burns out prior to replacement, light source shut off will be determined, comparing with the value at zero calibration.

• Oil slick detecting condition setting

The oil slick on the surface of the water has a variety of forms, it may be in a lump or scattered. The light sensing part also senses different light signals, depending on the condition of the water surface, such as rippling or calm surfaces. The oil-on-water monitor allows optimum setting for such variations.

• Recognition of floating material setting

This function allows the instrument to be set to recognise a low reflectance material like drifting wood on the surface of the water, and will have the same affect as if the light source has been shut off.

DIMENSIONS Units:mm

DETECTOR

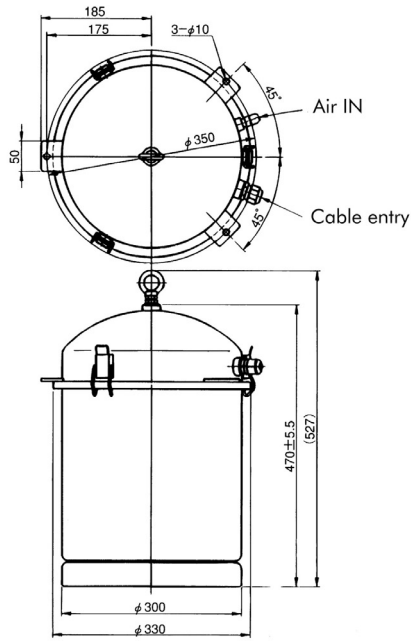

TRANSMITTER

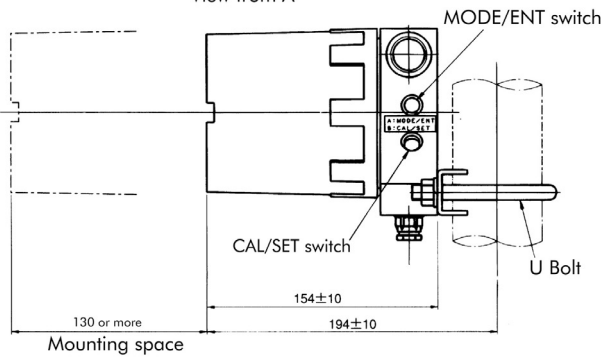
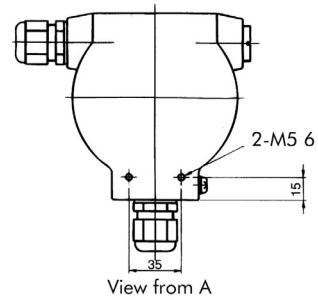
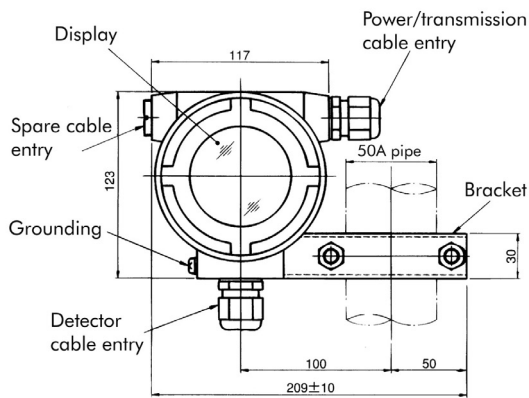

TERMINAL CONNECTIONS

Example: ODL-20

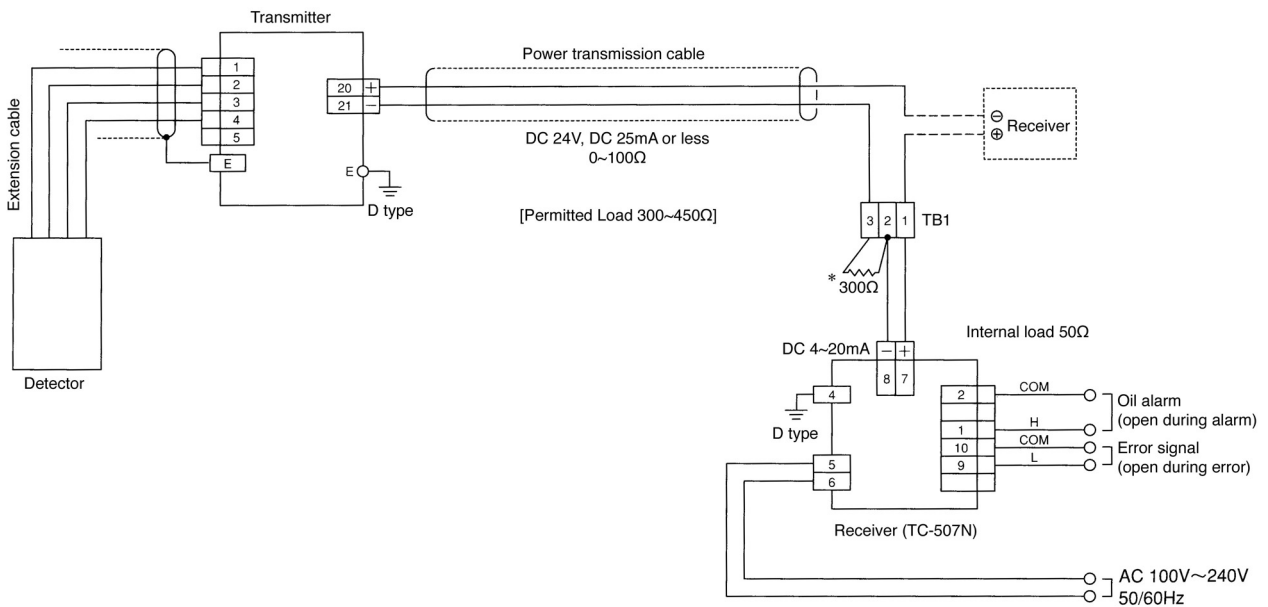

REQUIREMENTS FOR INSTALLATION

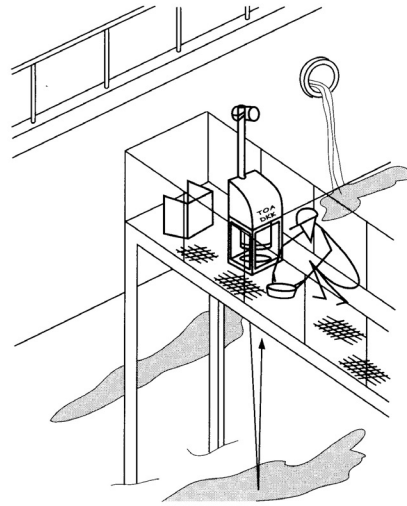
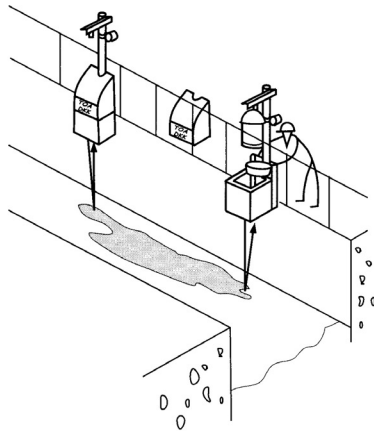

- When the instrument will be installed in locations subject to strong sunlight, use an appropriate sun-shade.
- Install the analyser at the location where the water flows smoothly. Avoid locations where there is turbulence.
- Install the analyser at the location where the monitoring surface will not be subjected to direct rainfall or direct wind attack, because a rippled water surface may make it difficult for oil film detection. For such locations, a protection against direct rainfall or wind attack will be required.
- Avoid locations where there is rising mist due to high water temperature. If this is unavoidable, supplying a gentle airflow will effectively clear the vapour away.
- Install the analyser at a location where water level changes are minimised. A pit with overflow will be required for such locations where there is excessive water level height variation.
- Install the analyser in a location where vibrations and mechanical shocks are minimised.
- Secure a space around the analyser and scaffolding if necessary for a safe and easy maintenance service.

• **Options**

RECEIVER DIMENSIONS

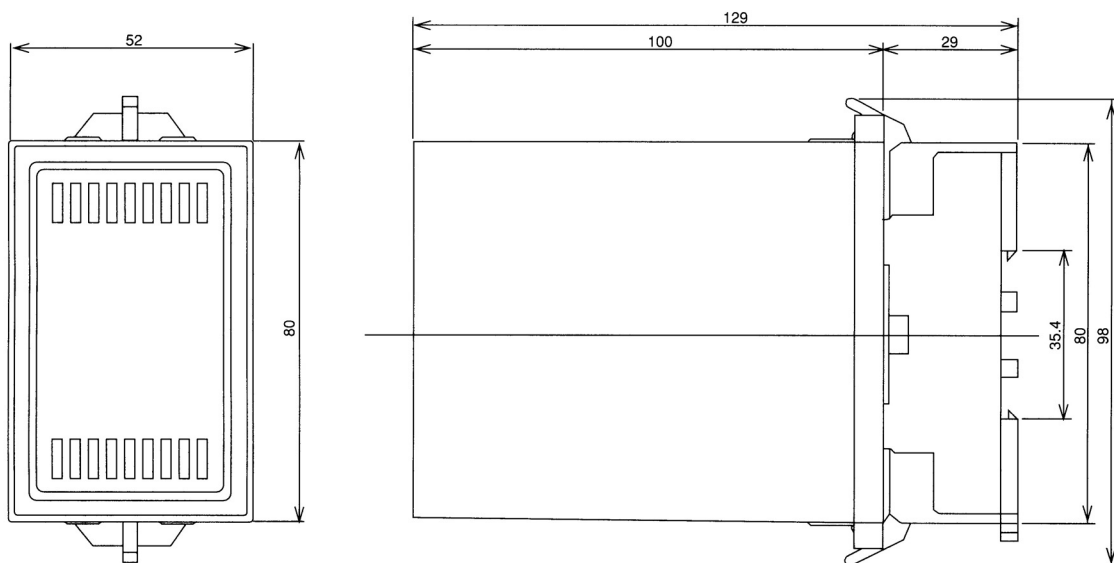

RECEIVER TERMINAL

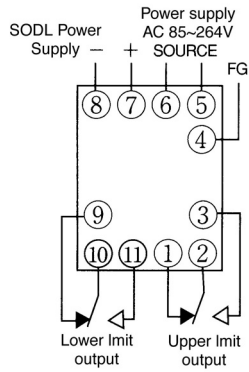

RECEIVER ALARM INTERFACE SPECIFICATIONS

Receiver model	Connection	Alarm interface output			Output relay
		Power off	Normal	Alarm	
TC-507N	NC-COM	ON	ON	OFF	Energized during alarm
	NO-COM	OFF	OFF	ON	Energized during alarm
TC-507R	NC-COM	ON	OFF	ON	Energized during normal conditions
	NO-COM	OFF	ON	OFF	Energized during normal conditions

Type	Model	Description	Type	Model	Description	Type	Model	Description
Holder		Pole • Wall mount type	Hood		Hood upper section	Miscellaneous		Calibration hanger
		Replacement type			Hood front section			
		Self stand type			Hood, reverse (self stand) holder (A)			
				Hood, reverse (pole • wall mount) holder (B)				
				Hood, reverse (replacement) holder for SODL-12 (C)				

PRODUCT CODE

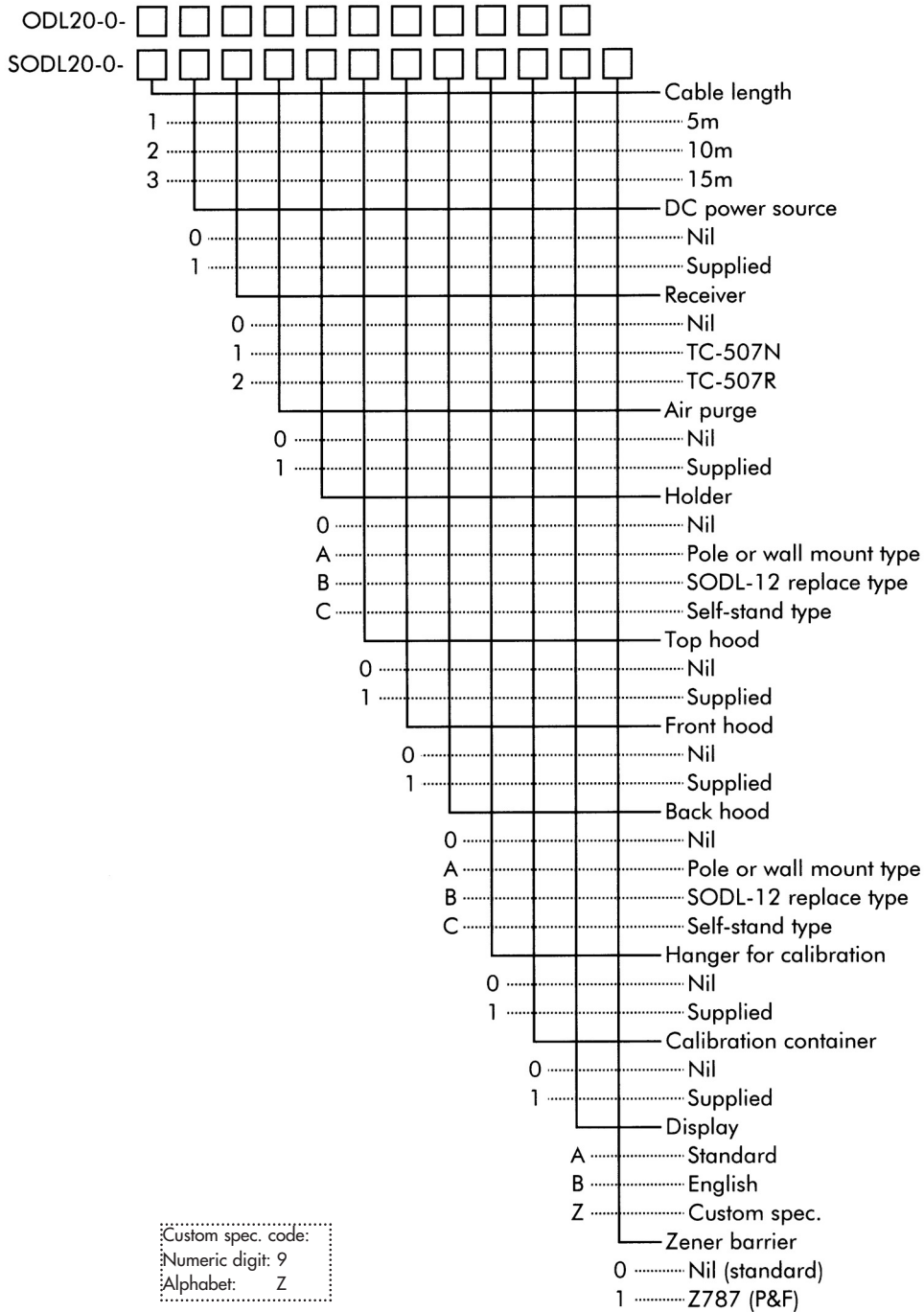

DKK-TOA CORPORATION



CAUTION

Do not operate products before consulting instruction manual.

International Operations:

DKK-TOA Corporation
 29-10, 1-Chome, Takadanobaba, Shinjuku-ku, Tokyo 169-8648 Japan
 Tel: +81-3-3202-0225 Fax: +81-3-3202-5685

Representative Office (Europe):

DKK-TOA European Representative
 St. Johns Innovation Centre, Cowley Rd., Cambridge CB4 0WS UK.
 Tel : +44 (0)1223-526471 Fax : +44 (0)1223-709239

<http://www.toadkk.co.jp>

Information and specifications are for a typical system and are subject to change without notice.