



Gas



Liquid & Slurry



Solid & Powder



Steam & Water

SENTRY MVS SAMPLER

Low Emission Samplers

MANUAL SAMPLING

The Sentry® MVS manual low emission sampler is ideal for sampling liquid and slurry material in refining, chemical, petrochemical and nuclear applications without emissions to the atmosphere or exposure to the operator. Dead volume is minimized by using a specifically designed close-coupled ball valve.

For nuclear applications, the Sentry MVS sampler normally is used to collect primary side (RCS) samples for laboratory analysis. However, it also can be used to collect samples on secondary side (PWR) or turbine building side (BWR).

MODELS

MVS

BENEFITS

The Sentry MVS sampler features a patented side-discharge dual needle assembly that ensures septum integrity and full venting of process vapors. This non-coring needle punctures the septum without coring it, allowing for full resealing of the septum when the sample bottle is removed. The tapered bottle shroud enables proper septum and needle alignment, preventing accidental spillage or needle breakage.

A variety of needle arrangements and sample bottle sizes are available to meet most sampling requirements. Additionally, a tube stub option is available for high viscosity fluids or slurries that contain particulates.

Since operator safety is of the highest concern, the sampling valve interface features an adjustable throttle stop and spring-loaded (deadman's) shut-off handle. This provides proper sample control and quick closure upon release of the sampling valve.

FEATURES

- Non-coring needle design improves septum integrity
- Spring-loaded (deadman's) shut-off handle helps to protect against over-filling
- Separate fill and vent needles reliably vent vapors
- Simple needle assembly replacement does not require replacing valve or disconnecting piping/tubing
- Variety of sizes and configurations to meet various application needs
- Close-coupled ball valve is specifically designed to minimize dead volume



Sample. Monitor. Measure.

SENTRY

Any Application. Anywhere.

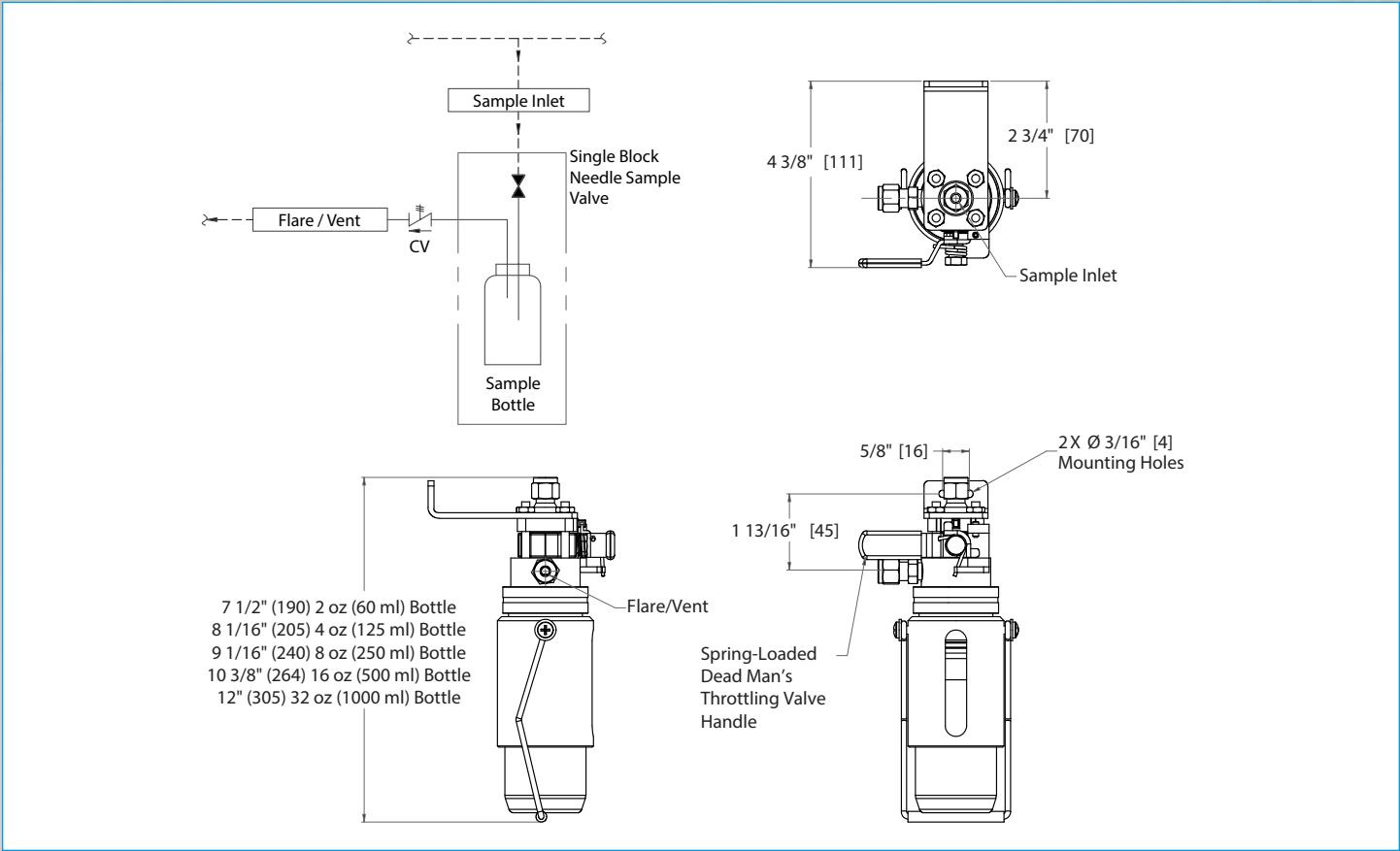

SPECIFICATIONS					
wetted materials	316 stainless steel, PTFE, Viton®, Kalrez®				
bottle shroud	nylon				
customer interface connection	1/4 in compression, 3/8 in compression or 1/2 in compression				
standard pressure rating	2200 psi at 100°F (150 bar at 38°C); 450°F at 100 psi (232°C at 7 bar)				
sampler interface	needle assembly (OD)*		bottle size and type	Boston round	Schott
	process	vent		2 oz (60 ml)	50 ml
	0.065 in	0.065 in	4 oz (125 ml)	100 ml	
	0.083 in	0.083 in	8 oz (250 ml)	250 ml	
	0.110 in	0.110 in	16 oz (500 ml)	500 ml	
			32 oz (1000 ml)	2000 ml	
	tube stub assembly (OD)		Boston Round bottle cap/thread interfaces per GPI finish standards. Schott bottle cap/thread interfaces per ISO 4796.		
	process	vent	Standard septum material is Teflon-coated silicone. Other bottle or septum arrangements are available.		
	3/16 in	9/64 in			
*other needle/tube stub arrangements available					

sentry-equip.com

966 Blue Ribbon Circle North, Oconomowoc, WI 53066 U.S.A. | +1-262-567-7256 | sales@sentry-equip.com

© 2016 Sentry Equipment Corp. All rights reserved. Sentry is a registered trademark of Sentry Equipment Corp. Viton is a registered trademark of The Chemours Company. Kalrez is a registered trademark of E.I. du Pont de Nemours and Company. It is solely the responsibility of end users, through their own testing and analysis, to select products and materials suitable for their specific application requirements, ensure they are properly installed, safely applied and properly maintained, and to limit their use to their intended purpose. Improper selection, installation or use may result in personal injury or property damage.

S-LS-SPS-00189-3 12-16



COMPANY WITH
QUALITY SYSTEM
CERTIFIED BY DNV GL
= ISO 9001 =