

SENTRY RB SAMPLER

Strip Samplers

AUTOMATIC SAMPLING

The Sentry® RB automatic strip sampler automates sampling of dry free-flowing and non-free-flowing materials such as granules, powders, flakes or pellets from gravity chutes and hoppers. A strip sampler captures a sample strip across the diameter of a process stream, and is used in situations where product segregation exists.

To obtain a sample, the Sentry RB sampler's air cylinder moves a sample tube through the process flow. Simultaneously, an auger conveys the sample material to the discharge point. The sample material is discharged through a flexible hose to a collection point. Sample volume can be changed at the sampler controller.

MODELS

RB

BENEFITS

With representative sampling, characteristics of each sample match that of the entire lot or batch—so samples are repeatable, leading to accurate sample analysis data. Automatic sampling ensures a sample can be easily and safely obtained with no need for direct human interface or interference. This ensures sample integrity as well as operator safety.

FEATURES

- Customized to meet various application needs
- Close tolerance between the auger and tube assures self-cleaning to help prevent cross-contamination
- Tube retracts from the line to avoid any restriction in the product flow
- Wetted components are 300 series stainless steel
- UHMW or PTFE seals
- White nitrile seals or gaskets
- Stroke lengths of 4, 6 and 8 inches (102, 152 and 203 mm)
- CE and ATEX compliant models available
- Includes air filter, regulator and gauge where applicable
- Optional release coating to ensure a non-stick surface
- QPQ hardening of contact surfaces available to protect against wear and abrasion
- Explosion proof (XP) motor available
- Custom mounting adapters for round, square or other shaped chutes or pipes
- Optional sample tube purge
- Pre-plumbed filter/regulator and solenoid valve available
- Optional purge ring for tube exterior
- All stainless housing and rails available



Sample. Monitor. Measure.

SENTRY

Any Application. Anywhere.

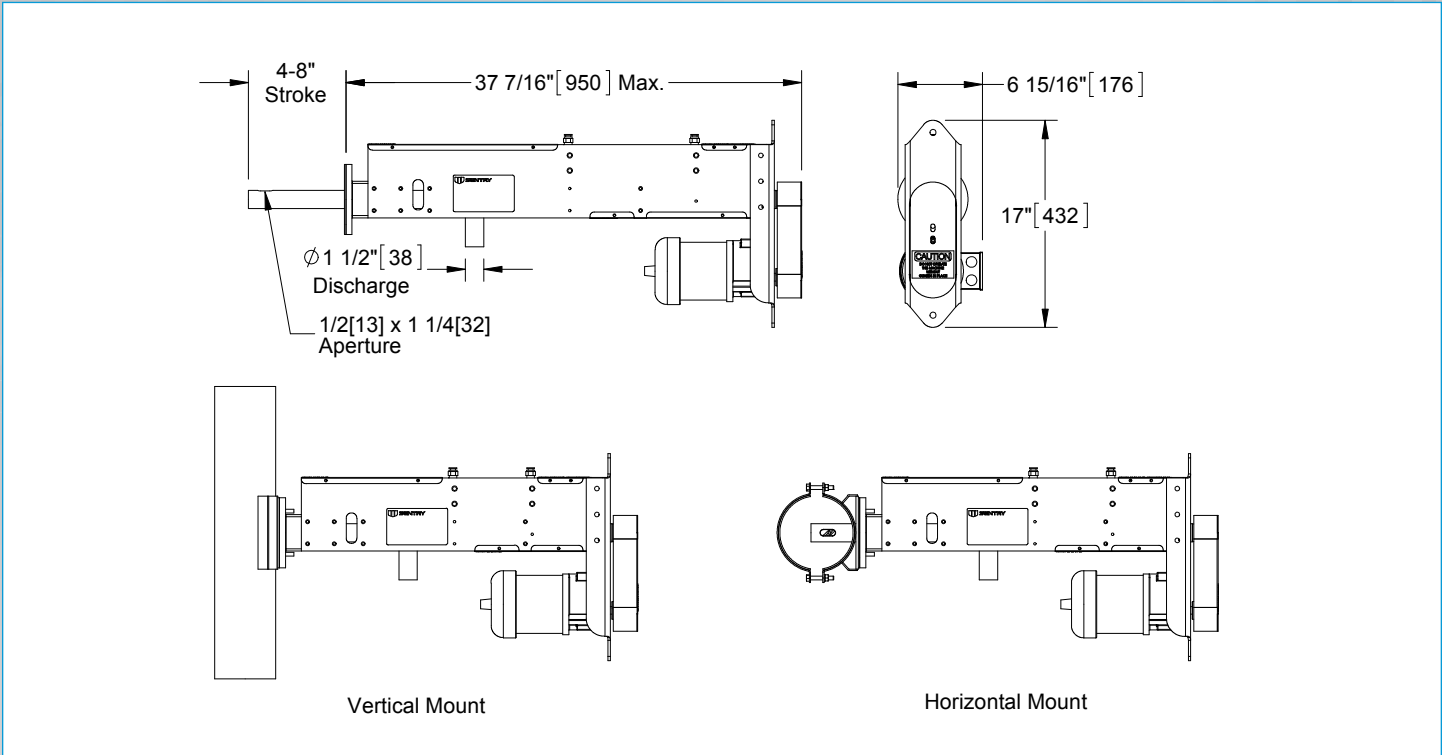

SPECIFICATIONS	
materials	300 series stainless steel, UHMW-PE, PTFE, white nitrile, aluminum cylinder
particle size	10 µm to 1/4 in (6 mm)
motor	1/6 HP gearmotor, 90 RPM, 115/230 V, 1 ph, 60 Hz; 110/220 V, 1 ph, 50 Hz TEFC
electrical requirements	115/230 V, 1 ph, 60 Hz or 110/220V, 1 ph, 50 Hz
temperature rating	-10 to 175°F (-23 to 79°C)
air requirements	air pressure of 60 to 80 psi (4.1 to 5.5 bar) recommended; air usage 32 in ³ (524 cc) per inch of stroke
suggested connection to sample discharge	flexible tubing to a collection container or indexing cabinet
recommended sampler location	positive or negative, horizontal or vertical dilute phase pneumatic conveying systems, bins, gravity spouts or hoppers
quantity of sample	determined by flow rate; 24 cc per revolution max.
collection containers	PET jar, 304 stainless steel jar, bag
pressure rating	up to 30 psi (2.1 bar)
shipping weight	approx. 60 lb (27 kg)



sentry-equip.com

966 Blue Ribbon Circle North, Oconomowoc, WI 53066 U.S.A. | +1-262-567-7256 | sales@sentry-equip.com



© 2016 Sentry Equipment Corp. All rights reserved. All product and company names are property of their respective owners. It is solely the responsibility of end users, through their own testing and analysis, to select products and materials suitable for their specific application requirements, ensure they are properly installed, safely applied and properly maintained, and to limit their use to their intended purpose. Improper selection, installation or use may result in personal injury or property damage.

S-SP-SPS-00173-6 6-16

COMPANY WITH
QUALITY SYSTEM
CERTIFIED BY DNV GL
= ISO 9001 =