

SENTRY MG SAMPLER

Strip Samplers

AUTOMATIC SAMPLING

The Sentry® MG automatic strip sampler automates sampling of dry free-flowing materials such as granules, powders, flakes or pellets from gravity chutes and hoppers. A strip sampler captures a sample strip across the diameter of a process stream and is used in situations where product segregation exists.

To obtain a sample, the Sentry MG sampler's air actuator rotates a slotted sample tube through the process flow. The material sampled is discharged through a flexible hose to a collection point. Material characteristics are not affected by the sampler because no moving parts convey the product to the sample container. Sample volume can be changed at the sampler controller. The sample probe is always in the product stream.

MODELS

MG-A | MG-E

BENEFITS

The Sentry MG sampler is designed to eliminate degradation of material and can be customized to meet various application needs. Its stainless steel tube easily detaches for cleaning to meet sanitation requirements.

With representative sampling, characteristics of each sample match that of the entire lot or batch—so samples are repeatable, leading to accurate sample analysis data. Automatic sampling ensures a sample can be easily and safely obtained with no need for direct human interface or interference. This ensures sample integrity as well as operator safety.

FEATURES

- Customized to meet various application needs
- Wetted components are 300 series stainless steel
- White nitrile seals or gaskets
- Designed to eliminate the degradation of sample material
- No moving parts in conveyance from sampler to container, keeping sample material characteristics consistent
- Stainless steel tube easily detaches for cleaning to meet sanitation requirements
- CE and ATEX compliant models available
- Available with pneumatic or electric actuation for flexibility
- Includes air filter, regulator and gauge where applicable
- Optional release coating to ensure a non-stick surface
- QPQ hardening of contact surfaces available to protect against wear and abrasion
- Explosion proof (XP) motor available
- Custom mounting adapters for round, square or other shaped chutes or pipes
- Same-side discharge where applicable
- Pre-plumbed filter/regulator and solenoid valve available



Sample. Monitor. Measure.

SENTRY

Any Application. Anywhere.

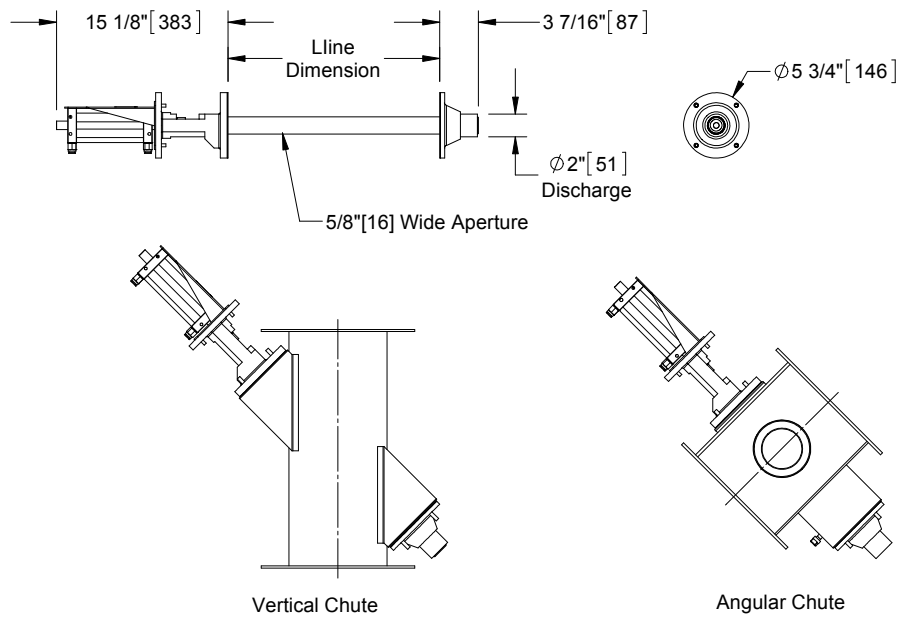

SPECIFICATIONS

materials	300 series stainless steel, white nitrile, acetal, aluminum actuator
particle size	10 µm to 1/4 in (6 mm); larger sizes upon request
temperature rating	-20 to 180°F (-29 to 82°C)
air requirements	air pressure of 60 to 80 psi (4.1 to 5.5 bar) is recommended; air usage 279 cc per inch of stroke
suggested connection to sample discharge	rigid metal or flexible tubing to a collection container or indexing cabinet
recommended sampler location	gravity chutes, hoppers and pipes
quantity of sample	determined by flow rate and aperture size
collection containers	PET jar, 304 stainless steel jar, bag
pressure rating	ATM
shipping weight	MG-A approx. 20 lb (9 kg) MG-E approx. 30 lb (14 kg)



sentry-equip.com

966 Blue Ribbon Circle North, Oconomowoc, WI 53066 U.S.A. | +1-262-567-7256 | sales@sentry-equip.com

© 2016 Sentry Equipment Corp. All rights reserved. All product and company names are property of their respective owners. It is solely the responsibility of end users, through their own testing and analysis, to select products and materials suitable for their specific application requirements, ensure they are properly installed, safely applied and properly maintained, and to limit their use to their intended purpose. Improper selection, installation or use may result in personal injury or property damage.

S-SP-SPS-00170-6 6-16



COMPANY WITH
QUALITY SYSTEM
CERTIFIED BY DNV GL
= ISO 9001 =