



BPRV Back Pressure Regulator/Relief Valve

**Maintain Constant Flow to
Your Analyzers**



Features

- Designed specifically for power plant sample flow rates
- Most effective way to assure constant flow through online analyzers
- Less prone to plugging and sticking than a pressure reducing valve
- Will not wire draw or erode in normal service
- Fail safe relief valve

Description

When installed in a system as shown below, the Back Pressure Regulator/Relief Valve (BPRV) will hold a constant pressure of approximately 20 psig (1.4 barg) at the analyzer inlet. This pressure is maintained independent of source pressure fluctuations or sample flow changes. If inlet pressure rises, the regulator opens to let excess flow pass through to drain. This flow is usually used as the grab sample. This unit also acts as a relief valve in the event of an over-pressure condition.

Constant Flow

With the circuit below, the severe service (pressure reduction) is handled by the VREL[®] or needle valve. The BPRV only has to control pressure between 20 psig (1.4 barg) and atmosphere. This allows very precise pressure control, minimizes plugging and ensures high reliability.

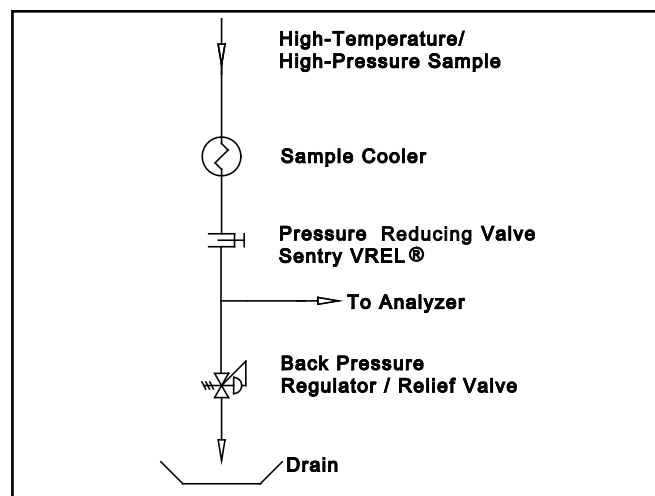

BACK PRESSURE REGULATOR/RELIEF VALVE

Operation

In the normal mode of operation, there should always be a flow from the exhaust port. This flow will increase with rising source pressures and decrease with falling source pressures, unless the VREL[®] is reset to maintain the total line flow at the set point. The Sentry valve also functions as a fail safe relief valve. The relieving capacity exceeds that of the most commonly used 1/4" relief valve. Since the BPRV is always in service, a malfunction is immediately evident. A relief valve can freeze with no outward indication until it fails to operate in an emergency.

Performance

The Sentry BPRV has a much flatter response curve than the standard back pressure valve designed for general process applications. For example, if the set point flow rate is 1200 cc/min, a 25% change in the flow produces only a 0.2 psi (0.014 barg) change in upstream pressure, 3 times more sensitive than a standard back pressure regulator.

SPECIFICATIONS

Model BPRVa-20
 Part No. 7-00868A
 Ambient Temperature . . . -40°F to 165°F (-40°C to 74°C)
 Wetted Materials 316 SS and Viton[®]
 Weight 2 lbs. (1 kg)
 Regulated Pressure Approx. 20 psig (1.4 barg)
 under normal operating conditions.
 Consult factory for other pressure settings.
 Connections 1/4" NPT Female
 Relieving Capacity 2 gpm at 10 psi (7.6 l/min at 0.7
 bar) buildup over set pressure

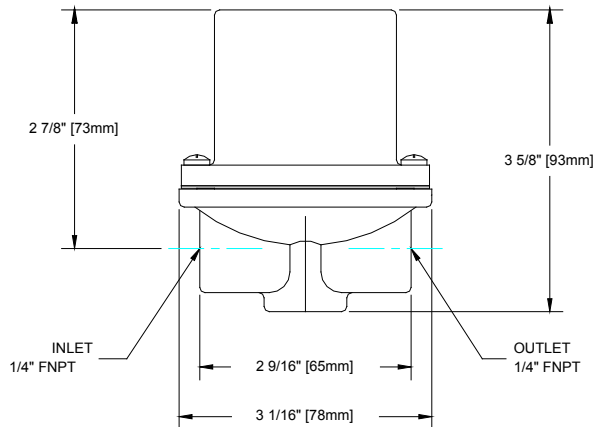

PERFORMANCE CURVE

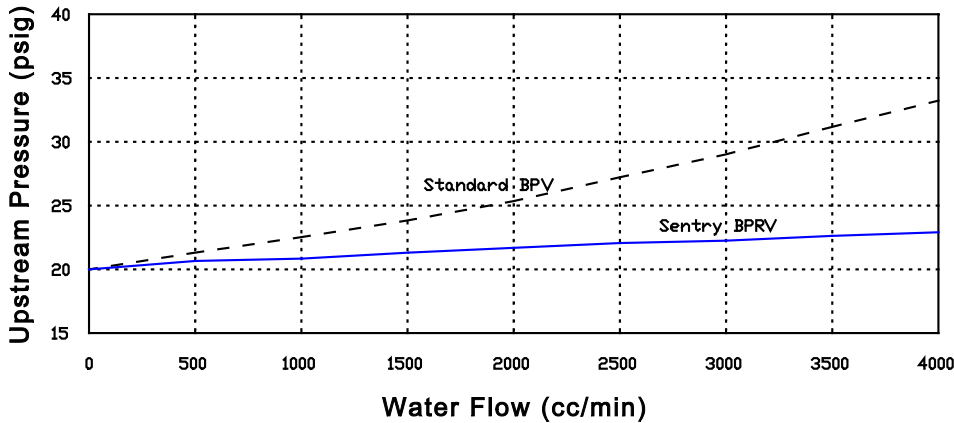

⚠ WARNING

It is solely the responsibility of the end-user, through its own analysis and testing, to select products and materials suitable for their specific application requirements, ensure they are properly installed, safely applied, properly maintained, and limit their use to their intended purpose. Improper selection, installation, or use may result in personal injury or property damage.



SENTRY EQUIPMENT CORP

966 Blue Ribbon Circle North
 Oconomowoc, WI 53066 USA
 Tel: 262-567-7256 • Fax: 262-567-4523

E-mail:
 sales@sentry-equip.com

Website:
 www.sentry-equip.com

**QUALITY MANAGEMENT SYSTEM
 CERTIFIED BY DNV
 ISO 9001:2008**

For further information, contact: