

# **TELEDYNE** **ANALYTICAL INSTRUMENTS**

## **MODEL 212R** **Trace Thermal Conductivity** **Analyzer**



**D**esigned to detect a specific impurity in a binary gas mixture, the 212R is also well suited for monitoring one component in more complex mixtures where the other gases have the same ratio to each other or have similar thermal conductivity coefficients.

### **SENSOR THEORY OF OPERATION**

The 212R uses a proven, heated 4-filament thermal conductivity detector (TCD) to effectively differentiate between the component of interest and the high purity sample gas. The detection method is an alternating current thermal conductivity cell with two flow paths - one for a known reference and another for the sample. On each side of the cell are sensitive resistive filaments on opposite legs of the bridge circuit.

The high gain system makes discernible any unbalanced condition of the bridge caused by a difference in the thermal conductivity of the two similar gases with unlike amounts of impurities. The signal generated by the TCD -- which is proportional to the component of interest -- is in turn amplified and delivered to the user's control system or recorder to monitor the process on a continuous basis. A PID controller is used to tightly control the temperature of the detector compartment to ensure stable performance over the entire operating temperature range.

The TCD and the analyzer's electronics are placed within a flush panel mount enclosure. The hinged front panel allows easy access to the analyzer without having to remove the unit from its mounting surface. The design also allows access to the sample selector calibration valve and flow control from the front.

A large LED display (3.5 digits) provides verification of the analyzer's performance from a distance. The 212R comes standard with a door, fitted with a viewing window, to prevent tampering of the controls under normal operating conditions.

The thermal conductivity detector used in the 212R is also flexible in terms of the binary applications the detector can be utilized in. Namely:

- 0-25 ppm H<sub>2</sub> in Ar
- 0-25 ppm H<sub>2</sub> in N<sub>2</sub> or O<sub>2</sub>
- 0-100 ppm N<sub>2</sub> in Ar
- 0-100 ppm He in Air
- 0-150 ppm N<sub>2</sub> in H<sub>2</sub> or CO
- 0-150 ppm N<sub>2</sub> in He
- 0-200 ppm Ar in O<sub>2</sub> (O<sub>2</sub> purity)

Flexibility, ease-of-use, high sensitivity, and competitive pricing make the Model 212R the analyzer of choice across a broad range of industries and applications.

### **FEATURES & BENEFITS**

- Proven, highly sensitive, simple-to-use TCD
- Improved temperature control via PID
- Easy access to analyzer controls
- Stainless steel sample system
- Triple Range Capability with Range ID contacts
- Large LED readout
- Helium leak detector-tight stainless steel sample system
- 3-way valve for sample, span, and zero gas selection
- Independent indication and control for sample, reference, and bypass flows
- 9-pin test port for fine tune adjustment and diagnostic testing (without opening unit)
- Cost effective alternative to complicated gas chromatographs and ion-mobility analyzers (radioactive tritium used in the detector) which leads to safety, transportation and disposal concerns

**Built for Reliability and Performance**

# Model 212R Specifications

## Specifications

Ranges: Application dependent; standard with triple range capability. Contact factory to verify application feasibility.

Range ID: 3 range ID contacts (dry contact closure)  
Local range ID LEDs also provided on the front panel

Outputs: Voltage – user selectable 0-1 or 0-5 VDC  
Current – 4-20 mA DC isolated

Detector: (4) filament thermal conductivity detector

Operating temperature: 20 to 35°C

Electrical: 110V or 220 VAC, 50/60 Hz (user specified) – 500 watts maximum

Display: Digital LED readout (3.5 digits)

Mounting: Flush panel mount (see dimensions)

Accuracy:  $\pm 2\%$  full scale for most binary mixtures

Response time:  
90% full scale response in less than 60 seconds for most applications

Stability: Less than 2% full scale drift over 24 hours

Sample / Calibration gas flow:

Sample:	0.3 scfh*
Zero & Span:	0.3 scfh*
Reference:	0.1 scfh*

\*Typical flowrates. May change slightly depending on application.

## Applications

- Air separation plants
- H<sub>2</sub> and He purification plants
- Synthetic gas plants
- Specialty chemical plants
- R&D labs

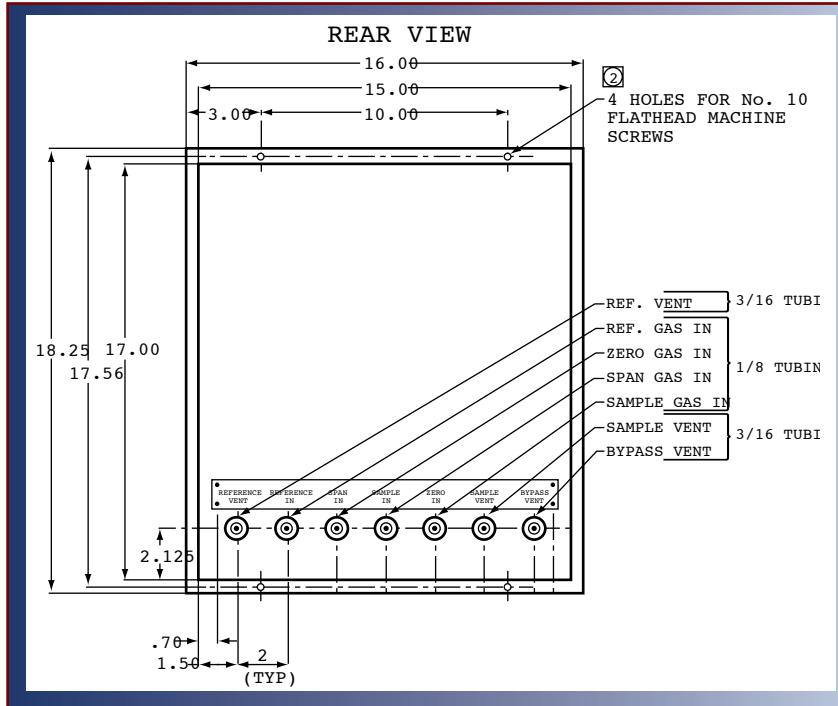
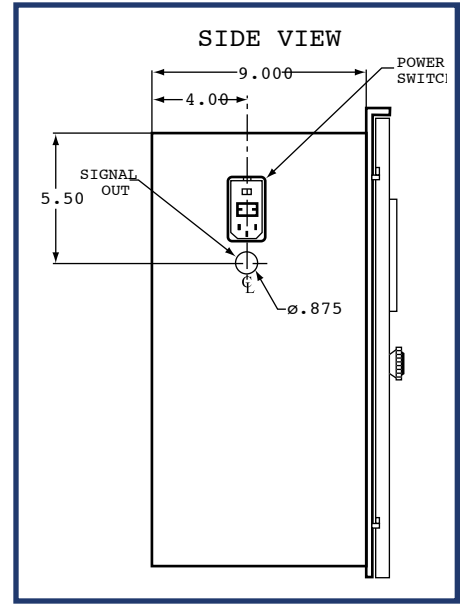

## TELEDYNE ANALYTICAL INSTRUMENTS

A Teledyne Technologies Company  
16830 Chestnut Street  
City of Industry, California 91748, USA

TEL: 626-934-1500 FAX: 626-934-1651  
TOLL FREE: 888-789-8168

Visit Our Web Site at:  
[www.teledyne-ai.com](http://www.teledyne-ai.com)

## Warranty

Instrument is warranted for 1 year against defects in material or workmanship

NOTE: Specifications and features will vary with application. The above are established and validated during design, but are not to be construed as test criteria for every product. All specifications and features are subject to change without notice.

