

# TELEDYNE ANALYTICAL INSTRUMENTS



Your optimal choice for Thermal Conductivity Analyzers

- Most complete product offering
- Superior performance
- Global approvals

**2000 SERIES**  
Thermal Conductivity Analyzers



## AIR SEPARATION

- Bulk gas purity monitoring
- Gas mixture blending
- Breathable diving gases
- Calibration gas blends
- Specialty gas cylinders for SF6, laser gas mixtures, etc.



## PETROCHEMICAL AND REFINERY

- H2 purity monitoring in recycle gas streams
- Redesulfurization process
- H2 reformer process
- Tail gas treatment units
- HYCO Syngas monitoring
- UOP (CCR) N2 header, lift gas H2 / HC safety analysis



## TURBINE GENERATORS

- Hydrogen purity analysis of purge cooling gas in the turbine generator housing to detect possible seal leaks



## NUCLEAR POWER GENERATION

- Hydrogen detection in the Containment Building in the event of a loss of coolant accident (LOCA) or steam line break (SLB)



## STEEL / HEAT TREATING

- Annealing furnace blanket gas monitoring
- Blast furnace monitoring
- Basic oxygen monitoring for process control purposes

# TAI Series 2000 TCD Sensing Solutions

The Series 2000 represents a complete line of Thermal Conductivity Detector (TCD) based analyzers which can be applied in a wide range of applications and industries.

By using field proven filament-based and semiconductor based TC detectors, Teledyne is able to continuously monitor hydrogen and a variety of other gases of interest in either binary or multi-component sample gas streams.

## SERIES 2000 PLATFORM

To contend with the numerous and varied analyzer requirements among industrial users, Teledyne has developed a feature-rich, user-friendly platform.

The Series 2000 comes with a standard software program incorporating such flexible features as (3) user-programmable ranges, automatic calibration, and customer selectable gas constituents.

For users who require a simple, low cost TCD device, Teledyne offers the Model 2000XTC 4-20 mA transmitter. The 2000XTC is an intrinsically safe monitor supplied with a galvanic isolator and power supply.



## FEATURES

- Customer selectable gas constituents; 11 gases, 110 combinations
- Automatic linearization
- Auto-ranging with manual override to lock into specific range
- Alphanumeric display which prompts and informs operator
- Auto and remote initiated calibration capabilities
- Bi-directional RS-232 serial digital communication port
- Extensive self-diagnostic capabilities
- 2 x programmable concentration alarm and system failure alarm relays

Built for Reliability and Performance



# TCD SENSOR SELECTION

Solution flexibility to meet unique monitoring needs

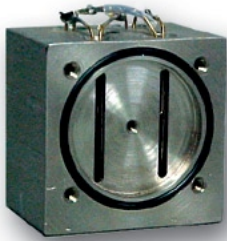

Filament based

Thermal conductivity is a basic property of gases that relates to their ability to conduct heat. Good conductors of heat, such as H<sub>2</sub> and He,

have a high thermal conductivity whereas poor conductors of heat, such as CO<sub>2</sub> and Ar, have low values. This ability to conduct heat forms the basis of detection.

The Series 2000 analyzes gas compositions by continuously comparing the sample gas with a reference gas (sealed or flowing) of known thermal conductivity. This comparison is performed in a 2-chamber detector cell block. Reference gas occupies one chamber and sample gas the other.

A pair of temperature-sensitive heated filaments is mounted in each chamber. These filaments are part of a Wheatstone Bridge circuit. Should the sample gas composition change, its thermal conductivity will also change, conducting different amounts of heat away from the sample gas filaments. Since the resistance of the filaments is a function of their temperature, the resistance changes when the sample gas changes.

Any such change results in an imbalance in the Wheatstone Bridge, resulting in an electrical signal proportional to the change. Since the temperature of the filaments is tightly temperature controlled, the Series 2000 provides an accurate measure of any change in the sample gas composition. Teledyne offers this cell design in a variety of wetted parts to contend with corrosive gas streams typically found within the hydrocarbon processing industry.

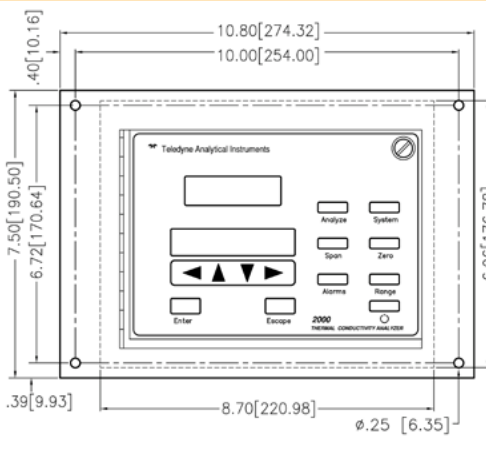

2000A  
Depth = 14.50[368.3]  
**Dimensions in inch [mm]**

2000B  
Depth=9.80[249]

2010  
Depth=8.41[213.54]

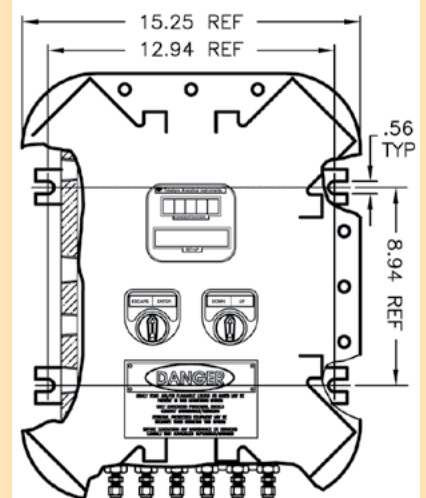
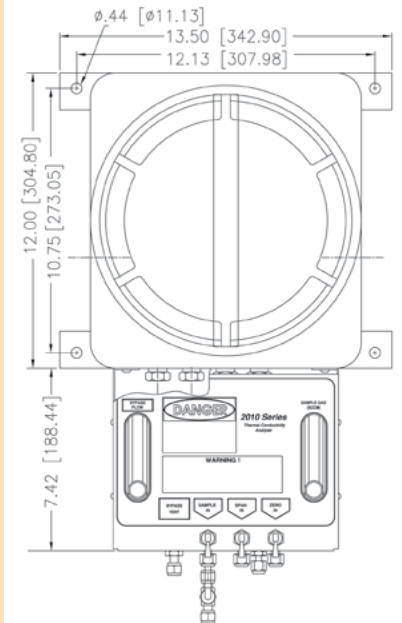

2020  
Depth=11[279.4]

## Sensor Operating Principle

The thermal conductivity sensor measures the concentration of a specific gas between a hot surface resistor and an ambient temperature reference resistor using the thermal conductivity coefficient of the gas itself.

## Sensor Description

The sensor structure consists of an integrated heater located on a thin electrical and thermal insulating membrane. Two thin film resistors are used for heating and measuring the temperature of the membrane. Two resistors are integrated on the silicon beside the membrane for the compensation of the ambient temperature changes.

Gases which have a lower density than air

(CH<sub>4</sub>) cause a decrease on the surface membrane temperature. On the other hand, gases with densities heavier than air (CO<sub>2</sub>) increase the temperature of the measuring resistor.

## Features

- Stable long-term operation
- Low power consumption
- Small dimensions
- Sealed reference
- Physical method for gas concentration measurement

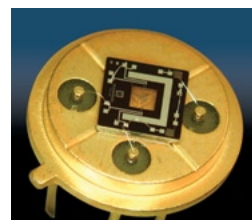

Semicon based

# SPECIFICATIONS – 2000 Series

	2000A	2000B	2010A	2010B	2020
Mounting:	Panel	Wall	Split / Panel	Split / Wall	Wall
Area classification:	General purpose, optional FM approved for Class I, Div 2. No Purge version available.		Analysis unit for explosion proof areas Class I, Div 1, Groups B, C & D; control unit for non-hazardous areas		Fully explosion proof, FM approved for Class I, Div 1, Groups B, C & D; CENELEC versions available
Ranges:	Three ranges plus a cal range, field selectable within limits (application dependent) and auto ranging				
Display:	Backlit 2 line alphanumeric LCD; 5 digit LED display				
Accuracy:	±1% of full scale for most binary mixtures at constant temperature; ±5% of full scale over operating temperature range once temperature equilibrium has been reached				
Response time:	90% in less than 10 seconds with a flow rate of 100 sccm				
System operating temperature:	32 to 122° F (0 to 50° C)				
Sensor type:	Standard TC cell (4-filament detector)				
Signal output:	Two 0-1 VDC (concentration and range ID); two 4-20 mA DC isolated (concentration and range ID)				
Alarm:	Two fully programmable concentration alarm set points and corresponding Form C, 3 amp contacts. One system failure contact to detect power, calibration, zero / span and sensor failure.				
Cell material:	Nickel plated brass block with nickel alloy filaments and stainless steel piping and end plates				
O/P Interface	Full duplex RS-232				
Max load impedance:	1000 ohms				
Reference gas:	Sensor selection dependent. Semicon-based = sealed. Filament-based = flowing or sealed (app. dependent)				
Tube connections:	1/4" compression fittings, 6 mm adapters optional				
Wetted parts:	Stainless steel, nickel, and gold (gold filament option); NACE compliant parts available as option				
Sample gas flow rate:	Recommended 0.1 to 0.4 SCFH				
Power requirements:	110 VAC, 50-60 Hz (220 VAC optional)				
Zero / Span drift:	±1 % of FS				
Pressure:	5-50 psig				

## OPTIONS

- C Integrally mounted auto-calibration valving
- H Stainless steel cell block with gold filaments (for gas streams with H<sub>2</sub>S)

- K 19" rack mount for 2000A
- L Gas selector panel for sample and cal gas selection and flow control
- N 220 VAC operation
- R Sealed reference (for filament-based TCD)

## **TELEDYNE ANALYTICAL INSTRUMENTS**

A Teledyne Technologies Company  
16830 Chestnut Street  
City of Industry, California 91748, USA

TEL: 626-934-1500 FAX: 626-934-1651  
TOLL FREE: 888-789-8168

Visit Our Web Site at:  
[www.teledyne-ai.com](http://www.teledyne-ai.com)

## Warranty

Instrument is warranted for 1 year against defects in material or workmanship

NOTE: Specifications and features will vary with application. The above are established and validated during design, but are not to be construed as test criteria for every product. All specifications and features are subject to change without notice.

